

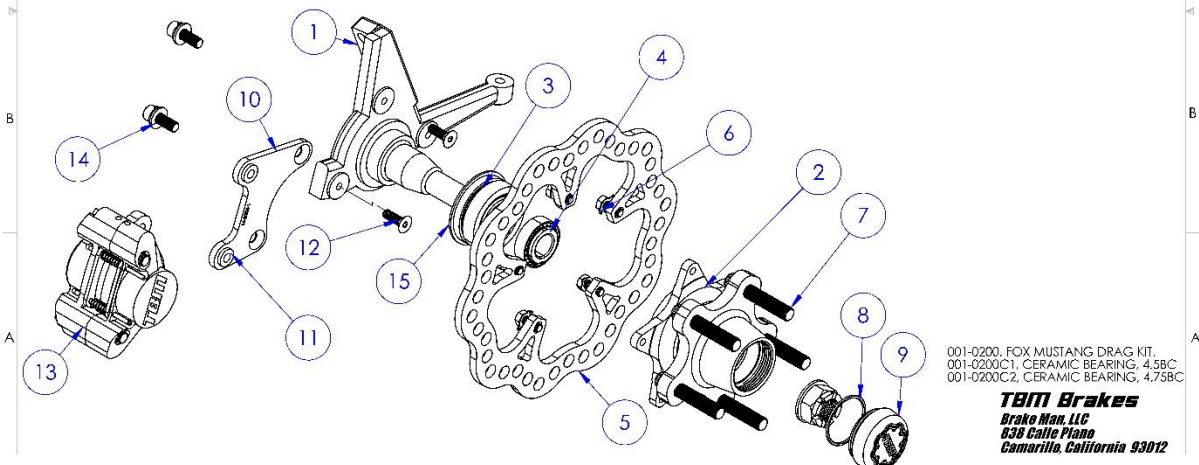

DRAG RACING BRAKE
SYSTEM INSTALLATION
INSTRUCTIONS
001-0200
FRONT, FOXBODY

ITEM NO.	PART NUMBER	DESCRIPTION	QTY.
1	FOX MUSTANG SPINDLE	MODIFIED FOX MUSTANG SPINDLE	1
2	TBM-8-0101 REV 2 SLIM	FOX MUSTANG DRAG HUB, 5 ON 4.5"	1
3	A5. AST_Bearings_LM48548_LM48510	A5 BEARING ASSEMBLY	1
4	A12. AST_Bearings_LM12749_LM12710	A12 BEARING ASSEMBLY	1
5	3-1075310552SD	10.75" X .3125 DRAG ROTOR, 5 ON 5.25"	1
6	011-0034	5/16"-18 X .75 HEX BOLT AND LOCKWASHER ASSEMBLY, 5 PER BAG	1
7	11-9803	1/2"-20 X 2" WHEEL STUD	5
8	7-2132	HUB CAP ORING SEAL.	1
9	8-001	HUB END CAP	1
10	16-0206, REV 78-93 MUSTANG FOX F1 3-1075375552SD RH	BRACKET, FOX MUSTANG, F1, 10.75 RTR. DRAG, RH SIDE	1
11	012-0010, .375x24 THREADED INSERT	3/8"-24 THREADED INSERT.	2
12	011-0034	5/16-18 X 1" FLAT HEAD SCREW.	2
13	002-0045SSP	F1 CALIPER ASSEMBLY	1
14	11-9897, 11-9913, 11-9879	3/8-24 X 1" SHCS, LOCK WASHER, FLAT WASHER	2
15	011-9150S	OIL SEAL, 9150S, *NOT USED ON CERAMIC BEARING KITS, 001-0200C1, 001-0200C2*	1



001-0200, FOX MUSTANG DRAG KIT.
001-0200C1, CERAMIC BEARING, 4.5BC
001-0200C2, CERAMIC BEARING, 4.75BC

TBM Brakes
Brake Man, LLC
838 Calle Plano
Camarillo, California 93012

- Remove the existing brake components
- Ensure the spindle is clean and free of debris
- Scuff the pad swept area of the rotor with a rotor hone or 80 grit sandpaper. This allows the pad to seat to the rotor during break in.
- Apply blue Loctite to the 1/2-20 studs and fasten them to the hub. Torque to 60 ft-lbs.
- Apply blue Loctite to the 5/16-18 hex bolts, use tab washer and fasten the rotor to the backside of the hub. Torque to 15 ft-lbs. Crimp both tabs on washer to bolt head.
- Mount the bracket to the spindle using the 3/8-16 x .75" FHCS. (For stock spindles, the supplied 5/16-18 x .75" FHCS may be used but drilling and tapping the spindles to 3/8-16 is recommended.)

- Slide hub assembly onto the hub and secure with spindle nut.
- Slide the caliper over the rotor and mount it to the bracket. Snug the 3/8-24 bolts, lock washer and washer. Check for proper radial and horizontal clearance between the rotor and the caliper.
- Insert the brake pads and cotter pins, and hold the pads against the caliper housing. Spin the hub assembly to check for contact between the rotor and brake pads. The F1 is a zero drag caliper and there should be no contact between the rotor and pads.
- If there is pad to rotor contact, determine which side is causing the interference. Shim the caliper or the bracket as needed using the supplied shim kit to center the caliper over the rotor for zero drag.
 - **What is required for one side of the car may not be the same as the other side. Check each side individually**
- Verify the pad material is sitting in the proper location in relation to top of the rotor [flush +/- .07"]
- Go back and tighten the caliper mounting hardware
- Connect the brake lines check for interference with any suspension or driveline components
- Bleed the entire brake system and verify proper caliper operation and release

Break-In

- All of our brake pads are pre-cured, which extends life and compound stability, and eliminates complicated bed-in procedure
- Take the vehicle out and verify proper brake operation at low speed before bed-in
- Bring the brakes up to operating temperature and ensure they are properly heated
 - *this may require some time and caution on the street
- you will feel the pedal come to you, and the brake torque output increase
- Allow the system to cool and the bed-in is complete
- If you observe material transfer to the rotors [dark streaking on the rotors], the system has not been fully bedded in.

If technical support and information is needed please contact us at 805-987-7867 or info@tbmbrakes.com